

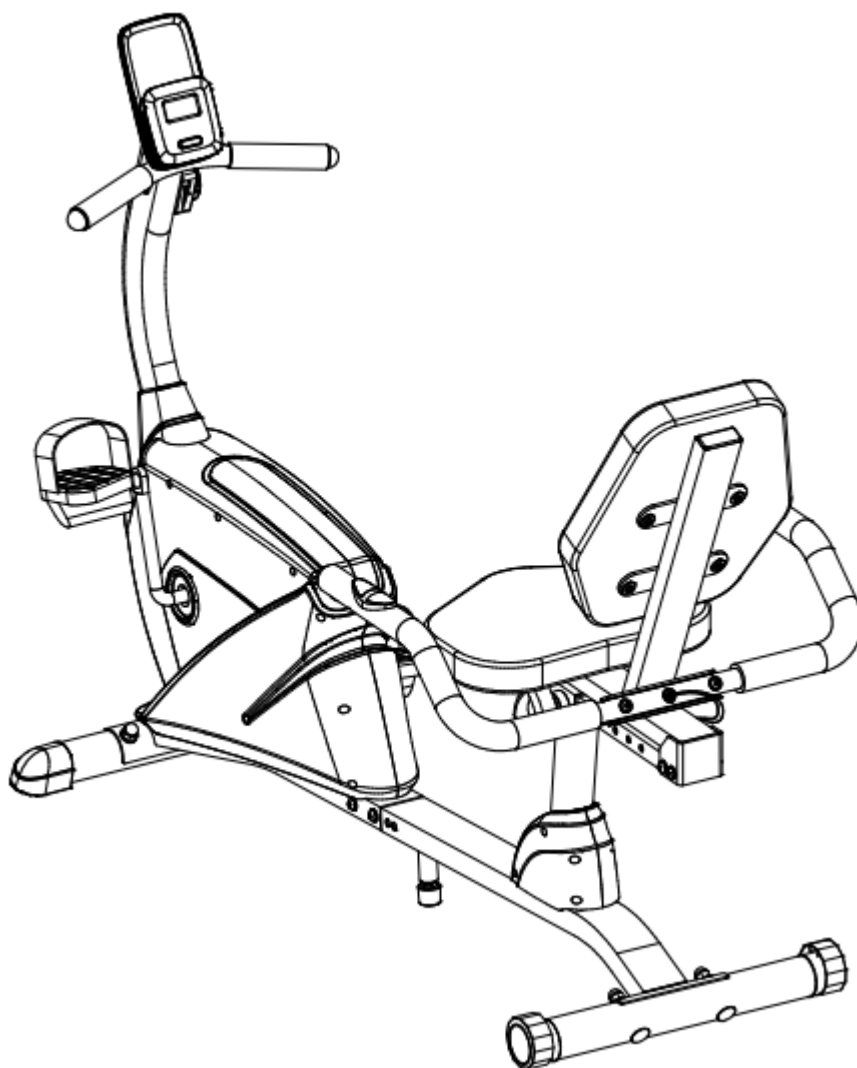

USER MANUAL – EN
IN 8244 Recumbent inSPORTline Varis



CONTENTS

- SAFETY INSTRUCTIONS..... 3
- DRAWING 5
- PARTS LIST 6
- ASSEMBLY 8
- CONSOLE 20
- APP PAIRING..... 20
 - FITSHOW..... 20
 - KINOMAP..... 21
 - ZWIFT 21
- TRANSPORT..... 22
- ADJUSTMENTS 22
- ADVANTAGES OF RECUMBITION..... 23
- EXERCISING INSTRUCTIONS 23
- MAINTENANCE 24
- STORAGE 24
- IMPORTANT NOTICE..... 24
- ENVIRONMENT PROTECTION 24
- TERMS AND CONDITIONS OF WARRANTY, WARRANTY CLAIMS..... 24

SevenSport s.r.o. reserves the right to make any changes and improvements to its product without prior notice. Visit our website www.insportline.eu where you will find the latest version of the manual.

SAFETY INSTRUCTIONS

- Read the manual carefully before first use and keep it for future reference.
- To ensure the best safety of the exerciser, regularly check it on damages and worn parts.
- If you pass on this exerciser to another person or if you allow another person to use it, make sure that that person is familiar with the content and instructions in these instructions.
- Only one person should use the exerciser at a time.
- Before the first use and regularly make sure that all screws, bolts and other joints are properly tightened and firmly seated.
- Before you start your work-out, remove all sharp-edged objects around the exerciser.
- Only use the exercise for your work-out if it works flawlessly.
- Any broken, worn or defective part must immediately be replaced and/or the exerciser must no longer be used until it has been properly maintained and repaired.
- Parents and other supervisory persons should be aware of their responsibility, due to situations which may arise for which the exerciser has not been designed and which may occur due to children's natural play instinct and interest in experimenting.
- If you do allow children to use this exerciser, be sure to take into consideration and assess their mental and physical condition and development, and above all their temperament. Children should use the exerciser only under adult supervision and be instructed on the correct and proper use of the exerciser. The exerciser is not a toy.
- Make sure there is sufficient free space around the exerciser when you set it up.
- To avoid possible accidents, do not allow children to approach the exerciser without supervision, since they may use it in a way for which it is not intended due to their natural play instinct and interest in experimenting.
- Please note that an improper and excessive work-out may be harmful to your health.
- Please note that levers and other adjustment mechanisms are not projecting into the area of movement during the work-out.
- When setting up the exerciser, please make sure that the exerciser is standing in a stable way and that any possible unevenness of the floor is evened out.
- No adjustable part may protrude and limit user movement.
- Always wear appropriate clothing and shoes which are suitable for your work-out on the exerciser. The clothes must be designed in a way so that they will not get caught in any part of the exerciser during the work-out due to their form (for example, length). Be sure to wear appropriate shoes which are suitable for the work-out, firmly support the feet and which are provided with a non-slip sole.
- Be sure to consult a physician before you start any exercise program. He may give you proper hints and advice with respect to the individual intensity of stress for you as well as to your work-out and sensible eating habits.
- Assemble the exerciser as per assembly instructions and be sure to only use the structural parts provided with the exerciser and designed for it. Prior to the assembly, make sure the contents of the delivery is complete by referring to the parts list of the assembly and operating instructions.
- Be sure to set up the exerciser in a dry and even place and always protect it from humidity. If you wish to protect the place particularly against pressure points, contamination, etc., it is recommended to put a suitable, non-slip mat under the exerciser.

- The general rule is that exercisers and training devices are no toys. Therefore, they must only be used by properly informed or instructed persons.
- Stop your work-out immediately in case of dizziness, nausea, chest pain or any other physical symptoms. In case of doubt, consult your physician immediately.
- Children, disabled and handicapped persons should use the exercise only under supervision and in presence of another person who may give support and useful instructions.
- Be sure that your body parts and those of other persons are never close to any moving parts of the exerciser during its use.
- When adjusting the adjustable parts, make sure they are adjusted properly and note the marked, maximum adjusting position, for example of the saddle support, respectively.
- Do not work out immediately after meals!
- Class – HC for home use
- Max. weight limit: 130 kg
- Console is powered by 2x AAA batteries

WARNING! A system for monitoring heart rate may not be accurate. Overloading during training may cause serious injury or death. If you feel any discomfort, immediately stop the exercise!

DRAWING

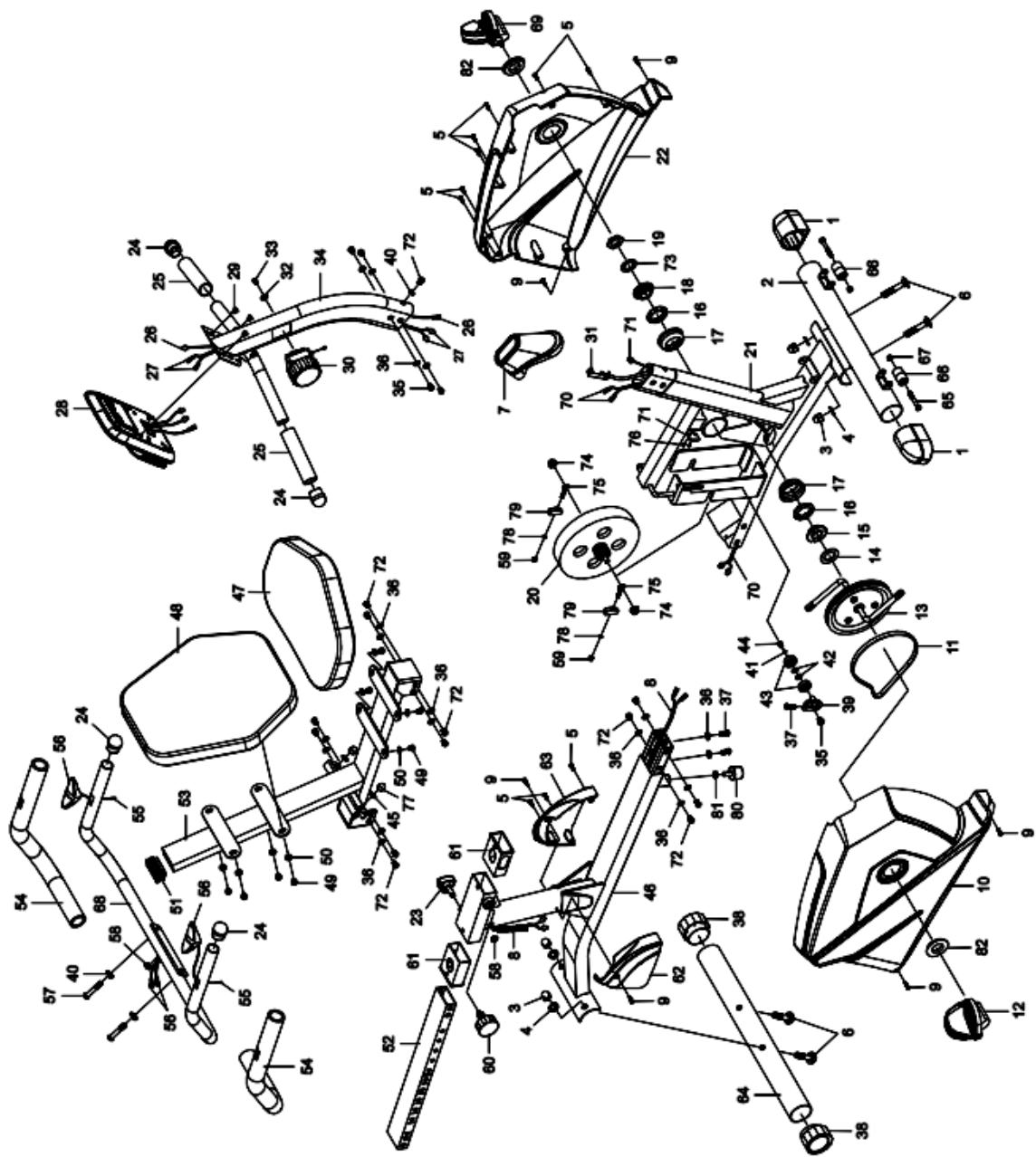

PARTS LIST

No.	Name	Qty.
001	Front Stabilizer End Cap	2
002	Front Stabilizer	1
003	Cap Nut M10	4
004	Curve Washer Ø10	4
005	Screw ST4.2x25	10
006	Bolt M10x57	4
007	Front Handlebar Post Cover	1
008	Middle Section Hand Pulse Sensor Wire L=1000mm	1
009	Pan Head Phillips Self Drilling Screw ST4.2x25	6
010	Right Cover	1
011	Belt 330J6	1
012	Right Foot Pedal YH-30X	1
013	Crank	1
014	Washer Ø34.5xØ23x2.5	1
015	Bearing Nut II 7/8"	1
016	Bearing	2
017	Bearing Cup	2
018	Bearing Nut I 15/16"	1
019	Hexagon Nut 7/8"	1
020	Flywheel Ø230	1
021	Front Main Frame	1
022	Left Cover	1
023	Triangle Knob M12x55	1
024	Round End Cap for Handlebar Ø25x1.5	4
025	Front Handlebar Foam Grip Ø30xØ24x160	2
026	Extension Sensor Wire L=500mm	1
027	Extension Hand Pulse Sensor Wire I L=500mm	2
028	Computer (HR-1586)	1
029	Bolt M5x10	4
030	Tension Control Knob	1
031	Tension Cable L=750mm	1
032	Big Washer Ø5xØ20x1	1
033	Bolt M5x20	1
034	Front Handlebar Post	1
035	Bolt M8x10	5

036	Washer Ø8xØ16x1.5	18
037	Bolt M8x30	3
038	Rear Stabilizer End Cap	2
039	Idle Wheel Bracket	1
040	Curve Washer Ø8xØ20x2	3
041	Washer Ø6xØ12x1	1
042	Washer Ø10.2xØ14x1	2
043	Bearing 6000ZZ	2
044	Bolt M6x10	1
045	Big Washer Ø8xØ20x2	2
046	Rear Main Frame	1
047	Seat Cushion 250x345x40	1
048	Back Cushion 310x345x40	1
049	Bolt M6x15	8
050	Big Washer Ø6xØ18x1.5	8
051	Back and Seat Support Bracket End Cap 23x53x2	1
052	Seat Sliding Tube	1
053	Back and Seat Support Bracket	1
054	Handlebar Foam Grip Ø30xØ24x510	2
055	Screw ST4.2x20	2
056	Hand Pulse Sensor with Wire L=750	2
057	Bolt M8x45	2
058	Wire Plug Ø12.1	2
059	Nut M6	2
060	Round Knob M16x1.5	1
061	Bushing	2
062	Right Rear Main Frame Cover	1
063	Left Rear Main Frame Cover	1
064	Rear Stabilizer Ø50x1.5x430	1
065	Bolt M6x48	2
066	Transport Wheel Ø23xØ6x32	2
067	Nylon Nut M6	2
068	Handlebar	1
069	Left Foot Pedal YH-30X	1
070	Extension Hand Pulse Sensor Wire II L=1000mm	2
071	Sensor with Wire L=450mm	1
072	Bolt M8x15	13
073	Washer Ø40xØ24x3	1

074	Nut M10x1	2
075	Eyebolt M6x36	2
076	Screw ST2.9x12	2
077	Cap Nut M8	2
078	Spring Washer $\text{\O}6 \times \text{\O}11.2 \times 2$	2
079	Tension Bracket	2
080	Rubber Bolt	1
081	Nut M8	1
082	Cover Cap $\text{\O}40 \times \text{\O}25 \times 10$	2

ASSEMBLY

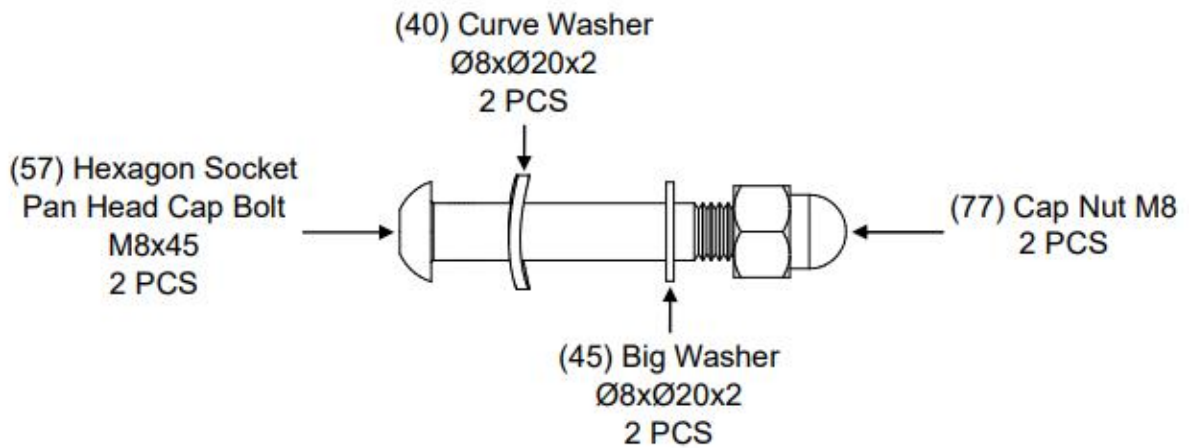
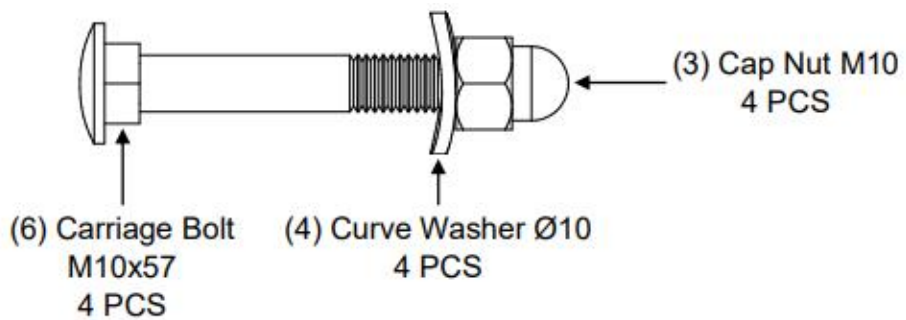

Allen key, 1x

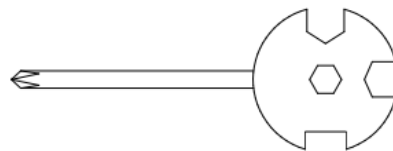

Wrench with screwdriver, 1x

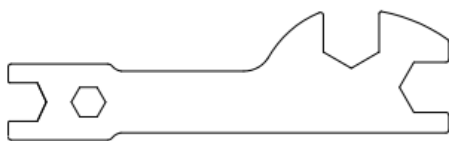

Wrench, 1x

Step 1

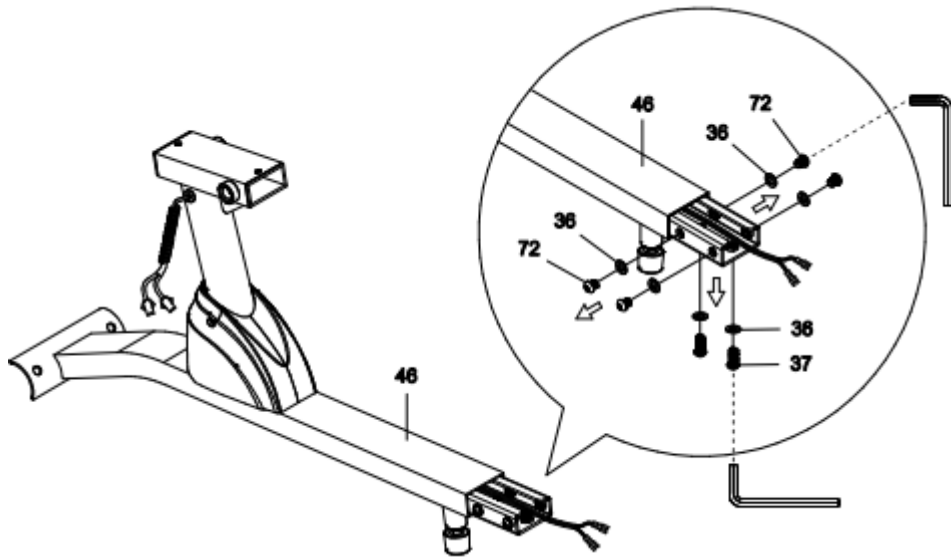

Remove bolts (37), (72) and washers (36) with Allen key.

Step 2

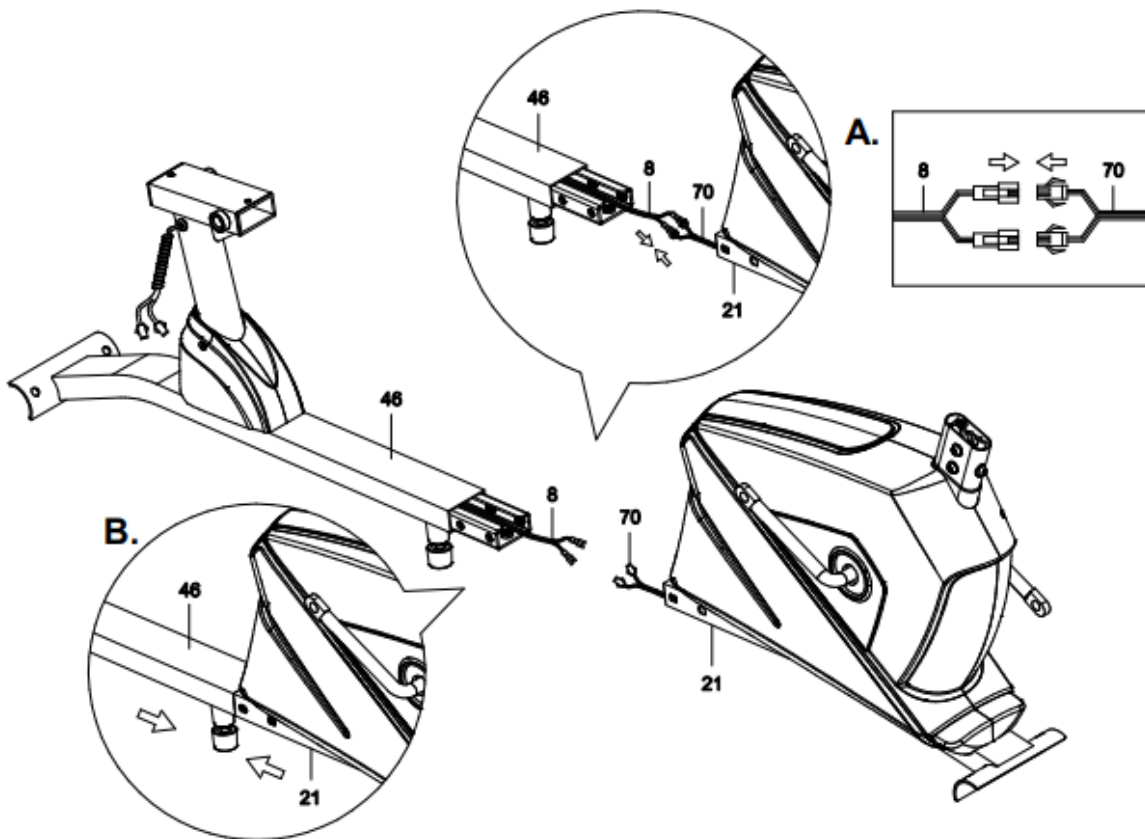

Connect the cables (8) leading from the rear frame (46) to the cables (70) from the main frame (21).
Align the holes, connect the rear frame (46) and the main frame (21)

Step 3

Connect the rear frame (46) and the main frame (21) with 2x screws (37), 4x screws (27) and 6x washers (36).

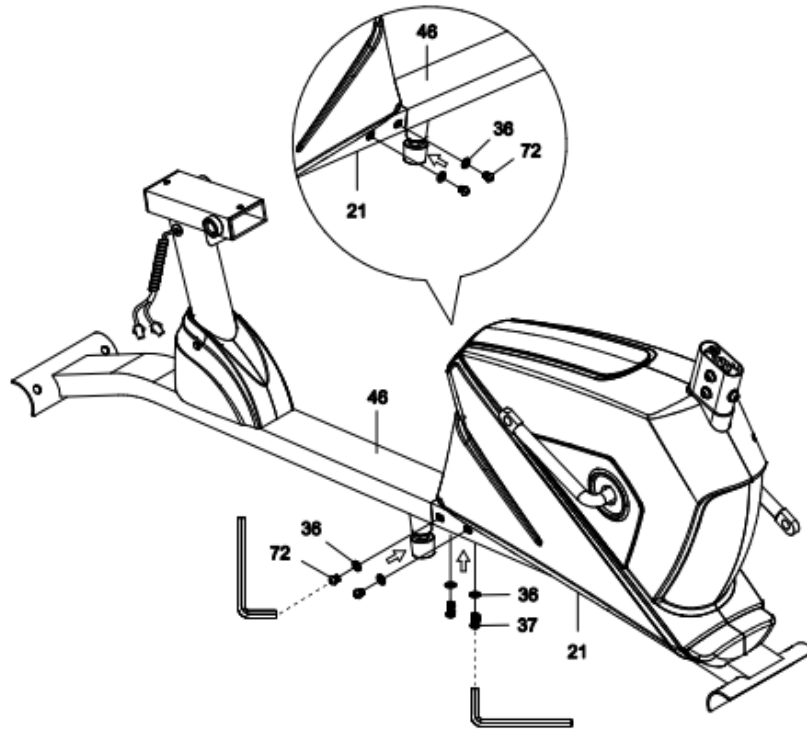

Step 4

Attach the rear stabilizer (64) to the rear frame (46) using 2x screws (6), 2x washers (4) and 2x nuts (3).

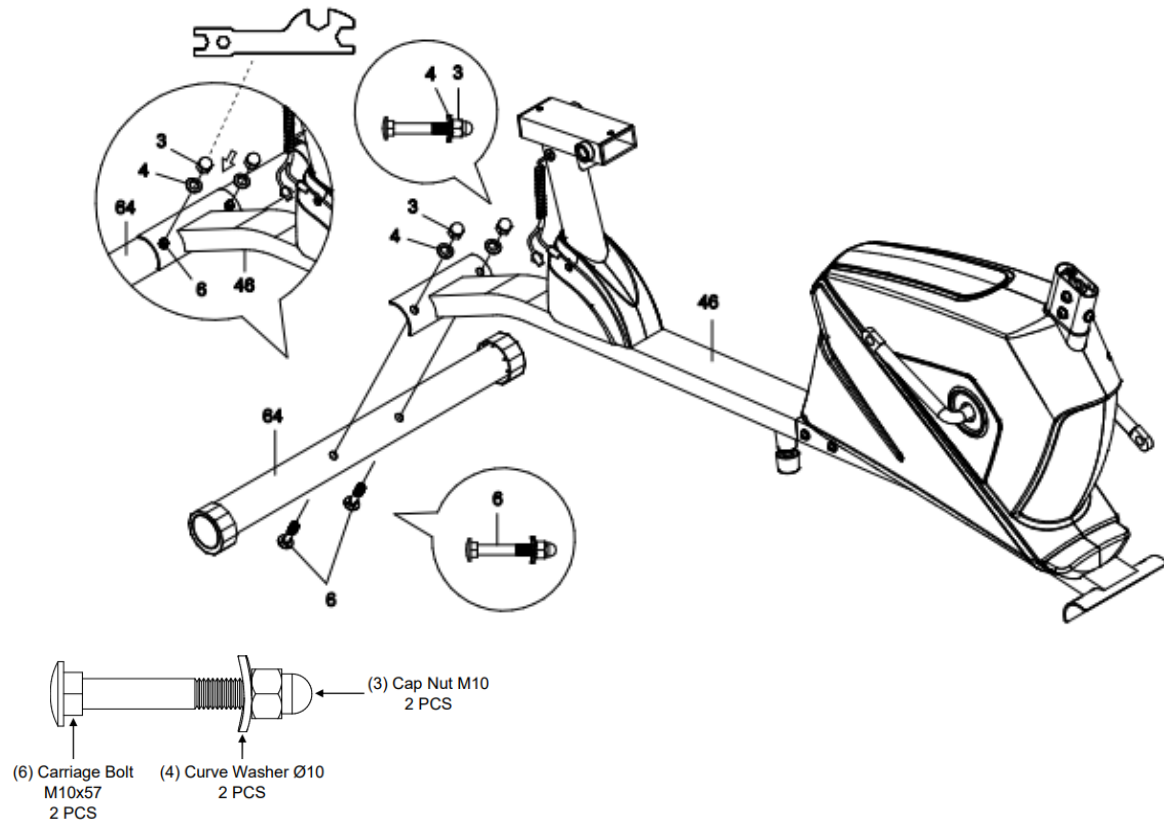

Step 5

Attach the front stabilizer (2) to the main frame (21) using 2x screws (6), 2x washers (4) and 2x nuts (3).

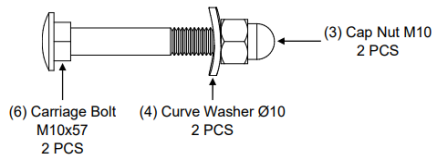
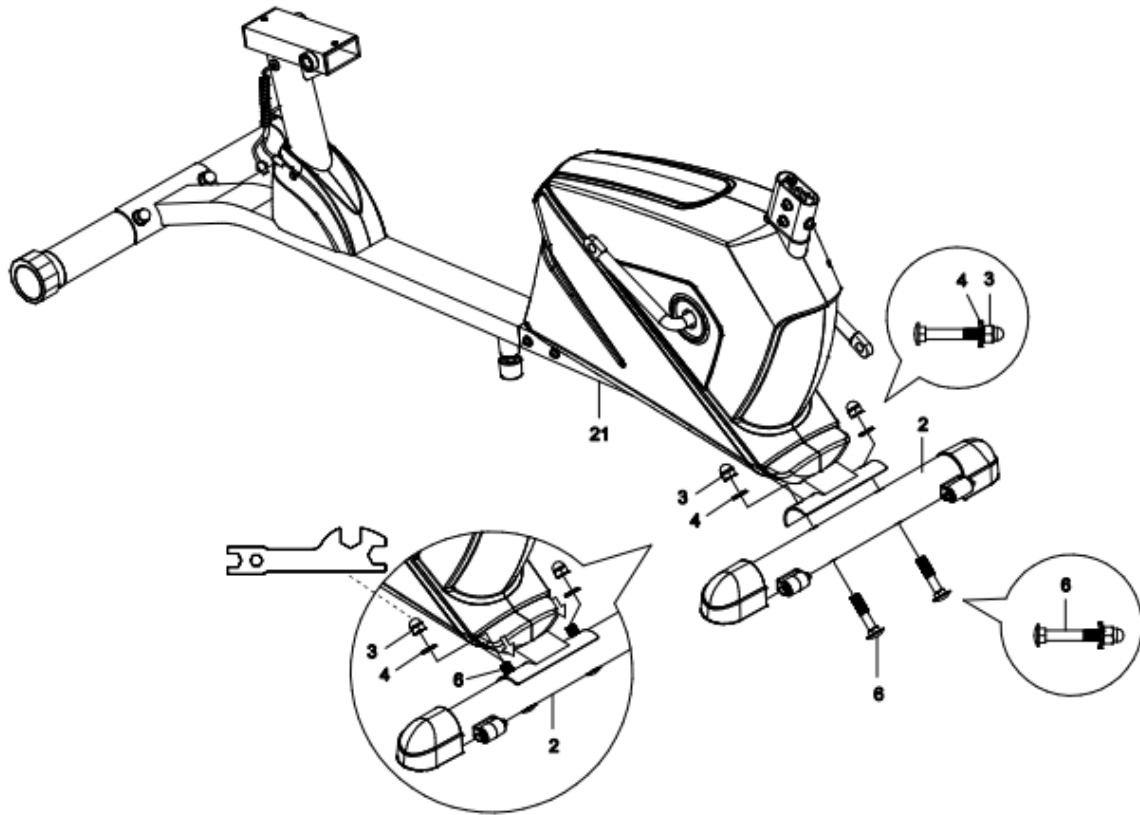

Step 6

Remove the screw (72), washer (40) and 4x screws (72), 4x washers (36) from the main frame. Pull the resistance (31), pulse detector (70), and sensor (71) cables from the main frame (21).

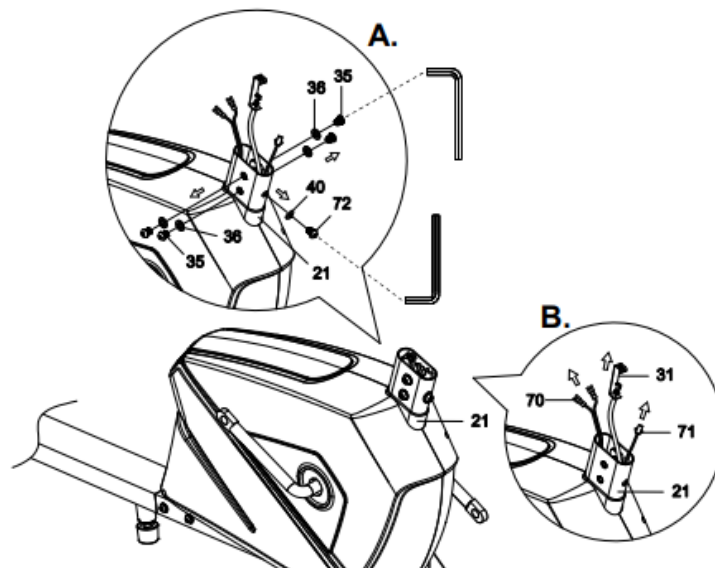

Step 7

Slide the post cover (7) onto the post (34).

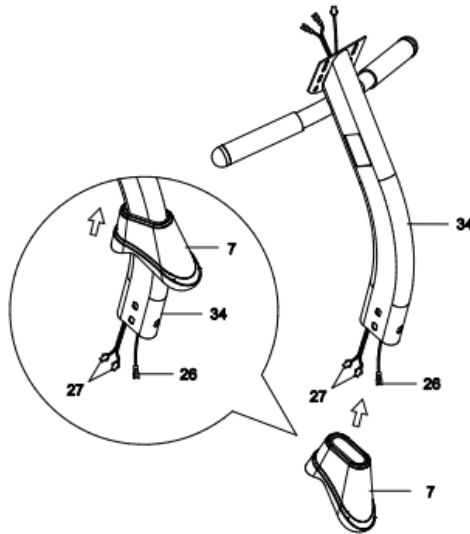

Step 8

We recommend asking another person for help with this step.

One person holds the post (34) and the post cover (7), the other person connects the cables.

- A. Route the resistance cable (31) from the main frame (21) to the top of the post's square hole.
- B. Connect pulse detector cable 1 (70) from main frame (21) to pulse detector cable 2 (27) from post (34).
- C. Connect the sensor cable (71) from the main frame (21) to the cable (26) from the pillar (34).
- D. Slide the post (34) onto the main frame (21) and align the holes.

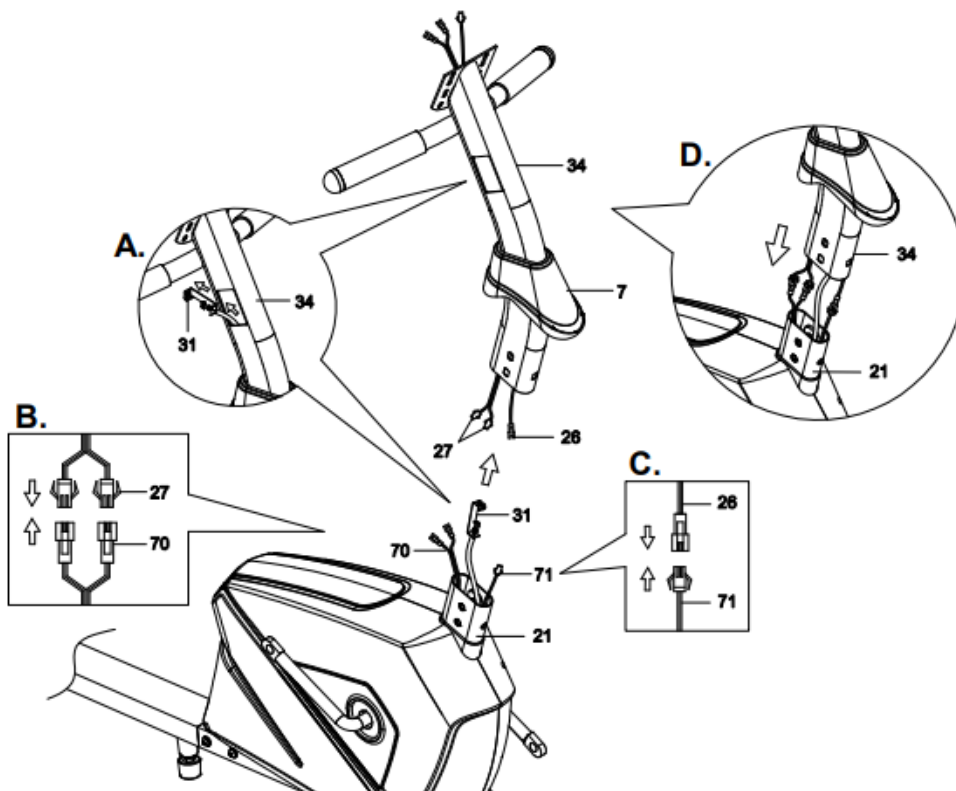

Step 9

Attach the post (34) to the main frame (21) with the screw (72), washer (40) and 4x screws (35), 4x washers (36).

Slide the post cover (7) down to the joint with the main frame (21).

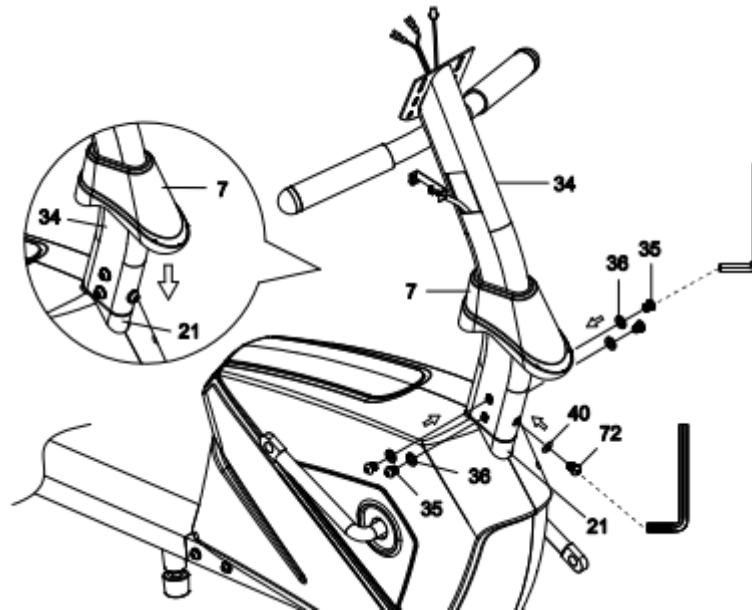

Step 10

Remove screw (33) and washer (32) from resistance adjustment knob (30).

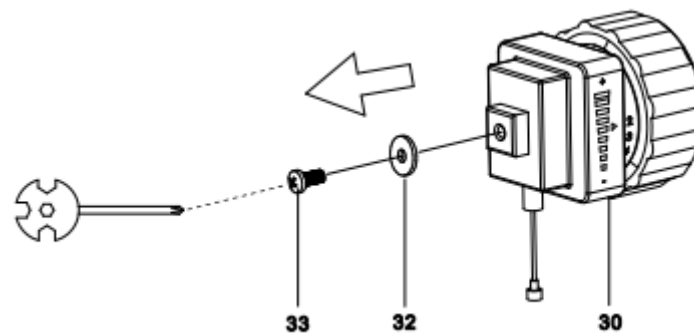

Step 11

- A. Slide the resistance control cable (30) leading from the rotary knob into the cable holder (31) leading from the post.
- B. Secure the cable (30) in the groove of the cable holder (31).
- C. Slide the cover on the cable (30) into the holder on the cable (31).
- D. Connect cables (30) and (31).

Attach the rotary knob (30) to the post (34) with the screw (33) and washer (32)

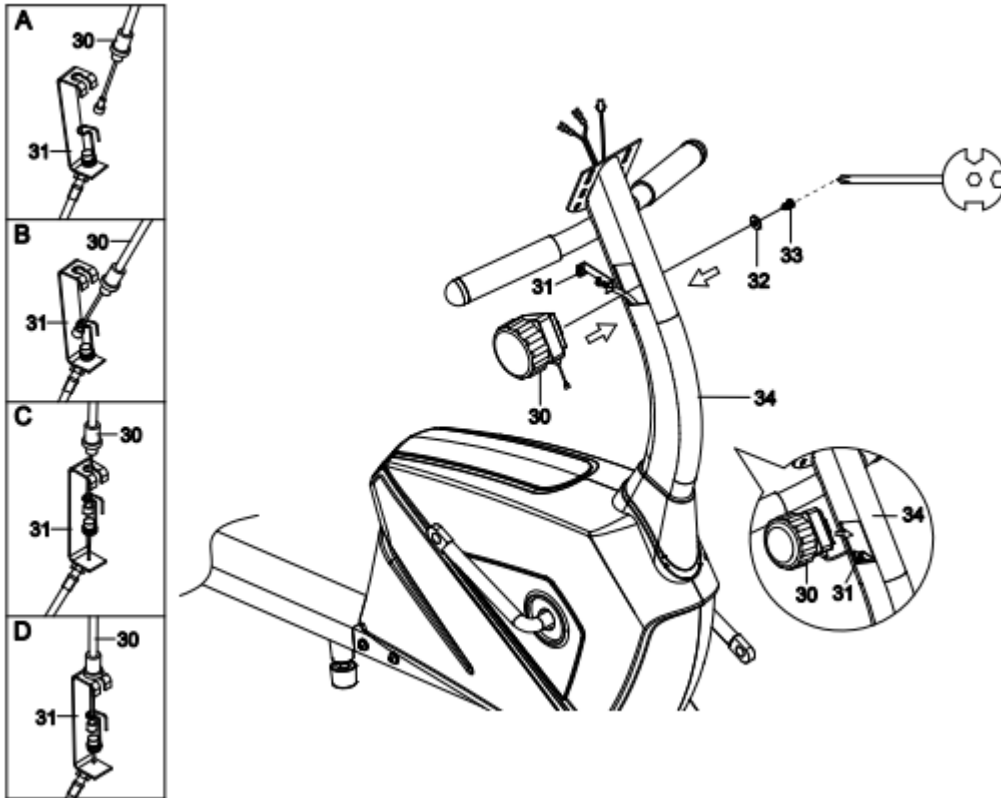

Step 12

Unscrew the screws (29) from the console (28).

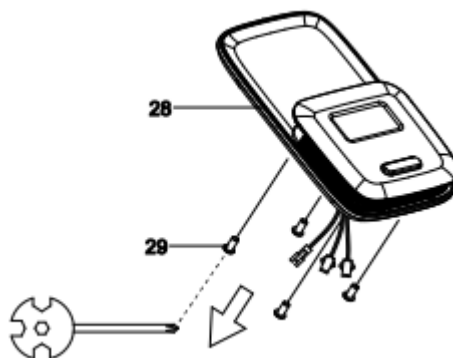

Step 13

We recommend asking another person for help with this step.

One person holds the console (28), the other person connects the cables.

Connect sensor cable (26) and pulse sensor cable 2 (27) leading from post (34) to cables from console (28). Then slide the cables into the post (34).

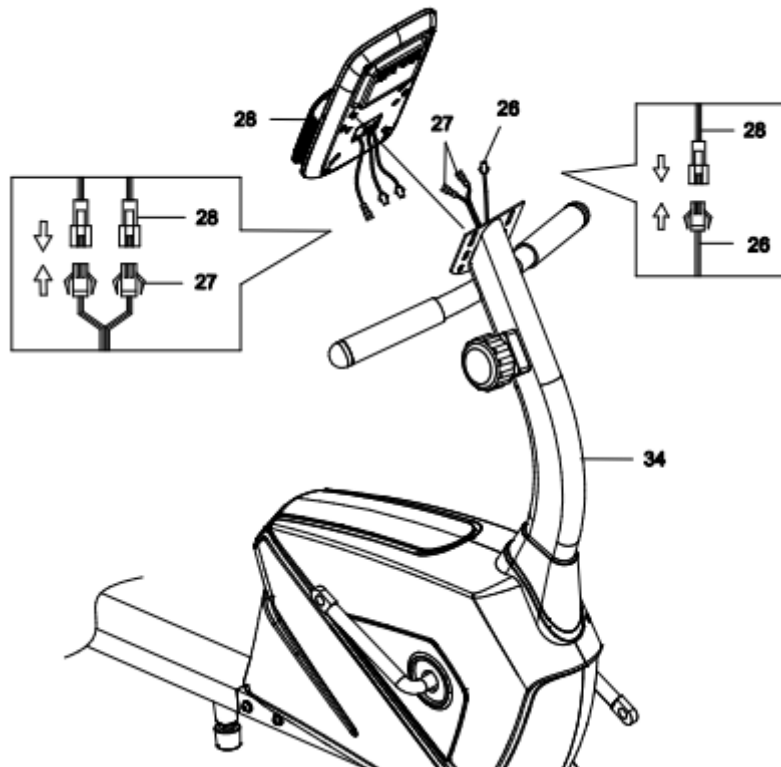

Step 14

Attach bracket (28) to post (34) with screws (29).

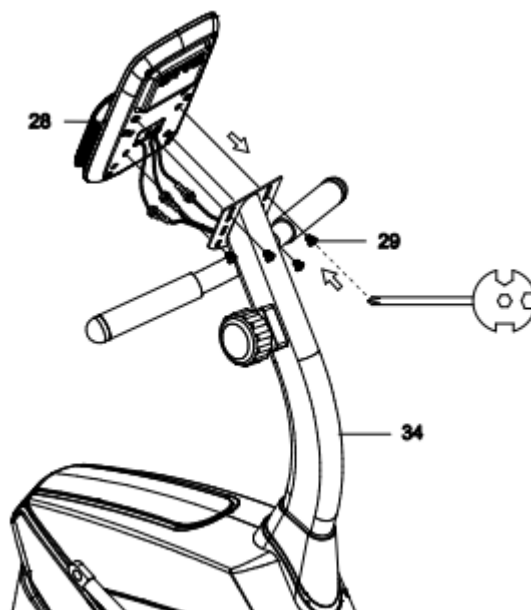

Step 15

Important: Pedals, straps and cranks are marked R (right) and L (left).

Attach the left strap to the left pedal (69). Attach the strap to the pedal. Adjust the length of the strap so that the foot is comfortably placed in the pedal.

Repeat for the right pedal (12).

Important: Pay attention to the direction of screwing the pedal.

Screw the left pedal (69) onto the left crank (13) counterclockwise. Then tighten with a wrench.

Screw the right pedal (12) onto the right crank (12) clockwise. Then tighten with a wrench.

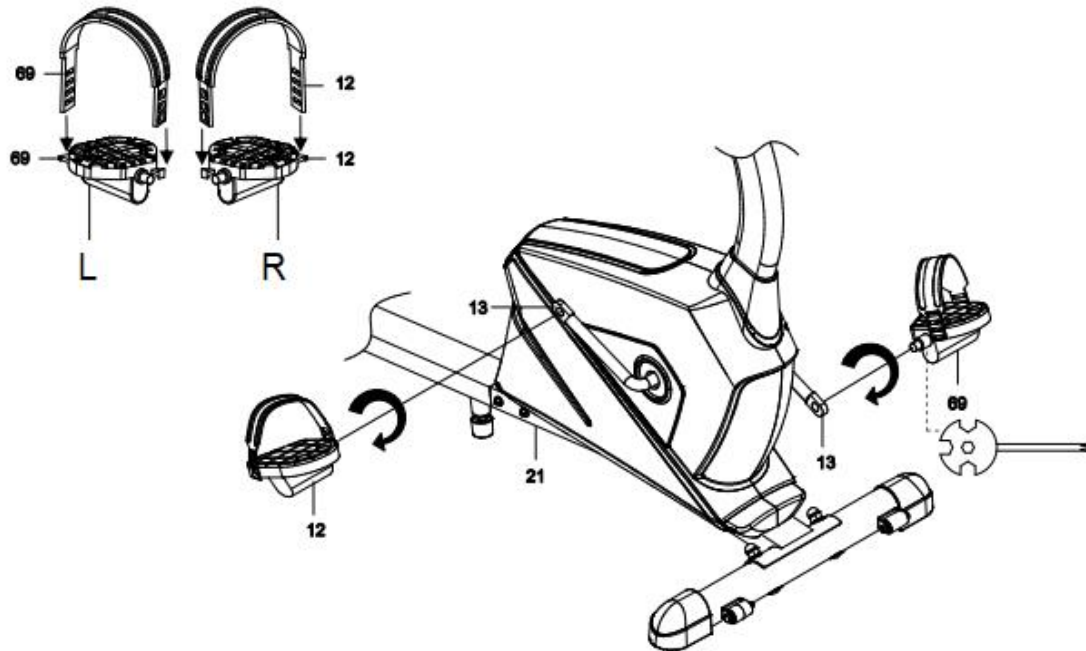

Step 16

Unscrew 8x washers (36) and 8x screws (72) from the seat and backrest frame (53).

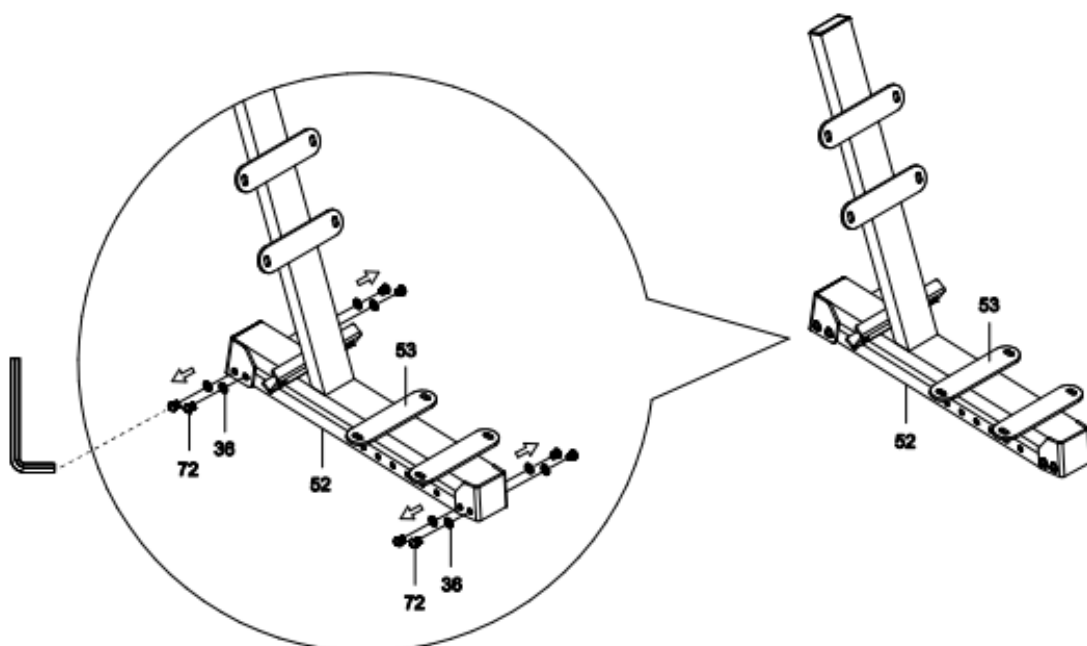

Step 17

Slide the seat and backrest support frame (52) into the back frame (46). Attach the seat frame (52) using the hand knob (60 and 23).

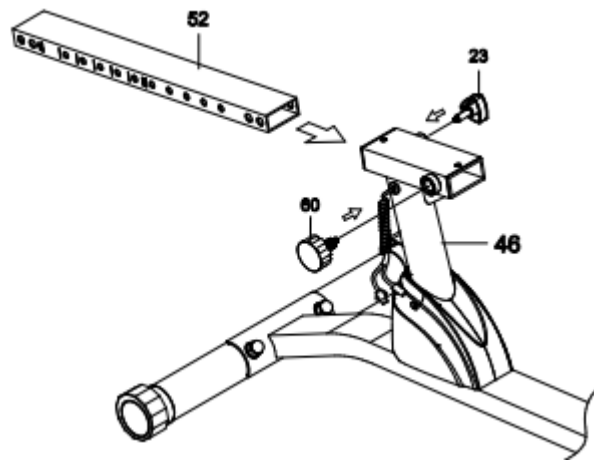

Step 18

Attach the seat and backrest frame (53) to the support frame (52) using 8x washers (36) and 8x screws (72).

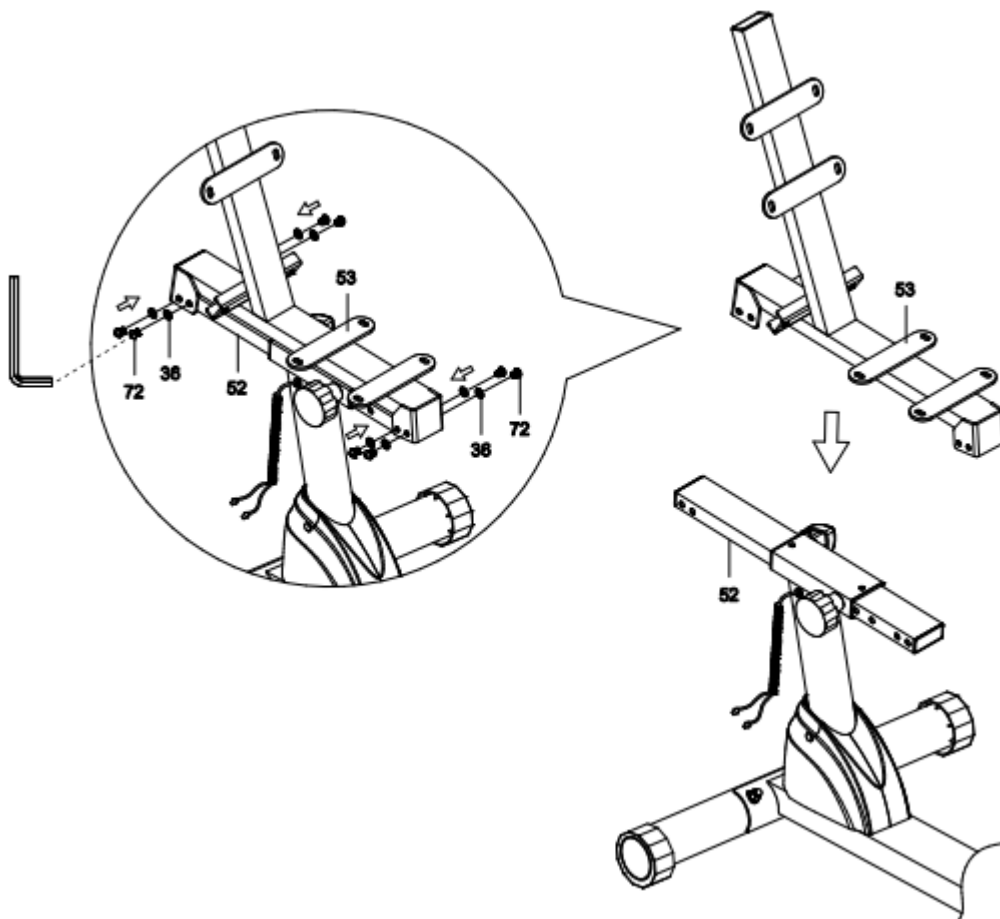

Step 19

- A. Attach the handles (68) to the seat and backrest frame (53) using 2x screws (57), 2x washers (40 and 45) and 2x nuts (77).
- B. Connect the cables (56) from the handles (68) to the cables (8) leading from the main frame (46).

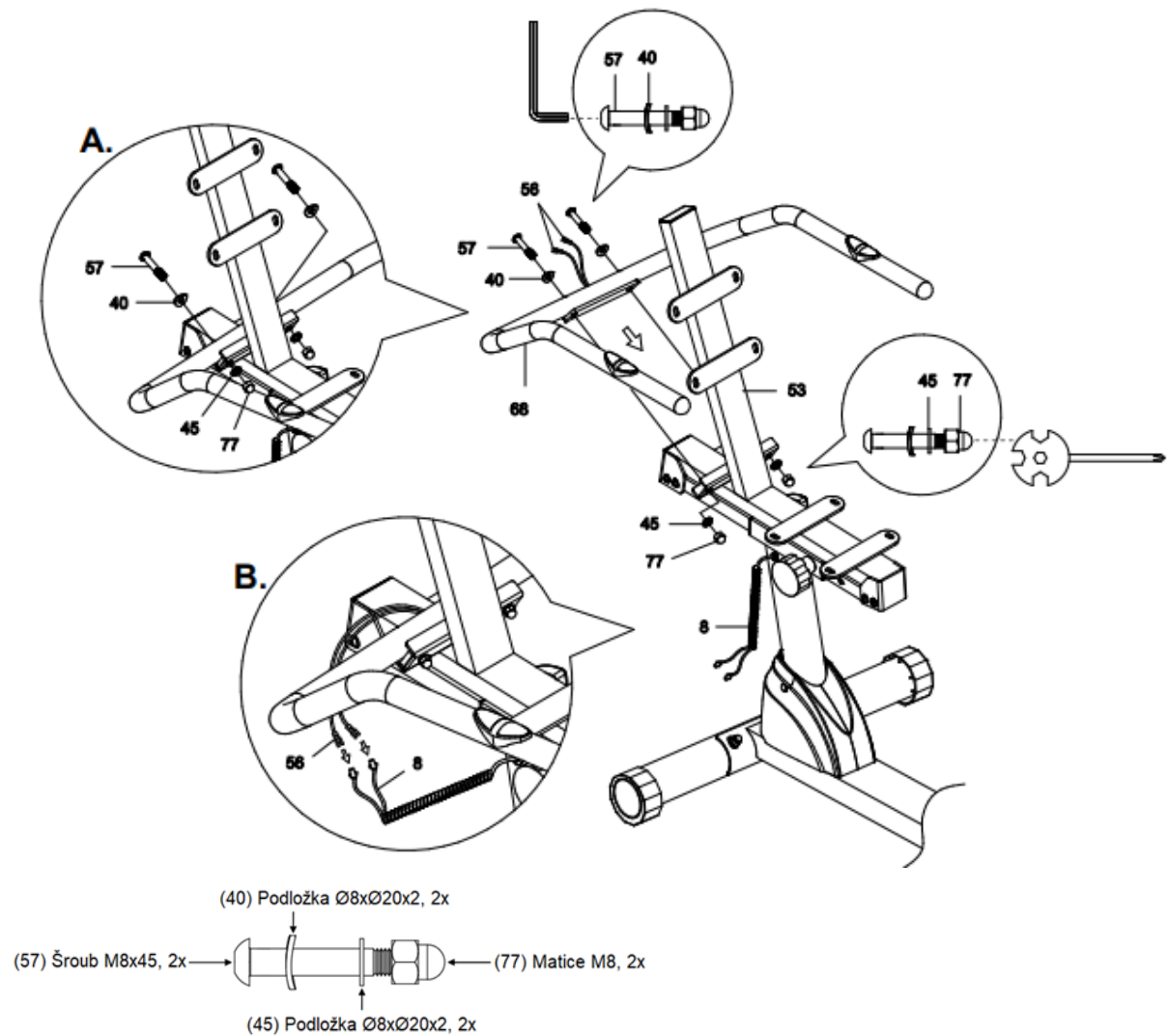

Step 20

Unscrew 4x screws (49) and 4x washers (50) from the seat (47). Attach the seat (47) to the seat frame using 4x screws (49) and 4x washers (50).

Unscrew 4x screws (49) and 4x washers (50) from the backrest (48). Attach the backrest (48) to the backrest frame using 4x screws (49) and 4x washers (50).

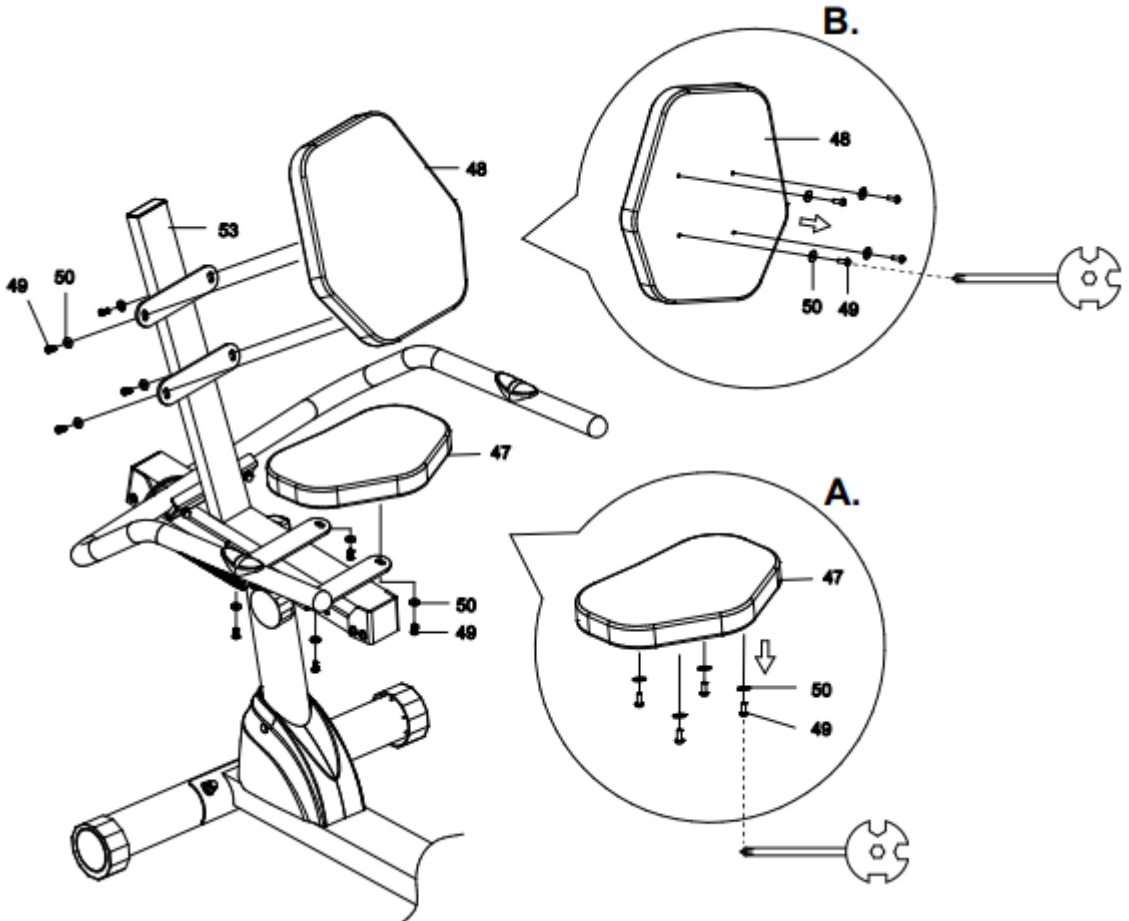

CONSOLE

Switch on / off

The console is switch on by pressing a button or moving the pedals. The console will automatically switch off after 4 minutes of inactivity.

Button

Press the button to switch the displayed value. Holding down the button for 3 seconds resets all values except the total distance traveled (ODO).

Functions

SCAN	The console displays data in a cycle every 6 seconds.
TIME	Duration of training, minute: second
SPEED	Speed
DIST	Distance during exercise
CAL	Number of calories burned. The value is indicative only, not for medical purposes
ODO	Total distance traveled. The value cannot be reset using the button. You reset the value by removing the battery.
PULSE	Displays the current heart rate. It is necessary to hold the sensors on the handles.

BATTERY REPLACEMENT

1. Remove the battery cover.
2. Remove the old batteries. Always replace both batteries.
3. Insert new batteries, pay attention to the polarity of the batteries.
4. Attach the battery cover.

APP PAIRING

Turn on Bluetooth on your smart device. Make sure you are within range of the connection. Select the app.

FITSHOW

Download the FitShow app using the QR code or search for the app on Google Play Store (android) or App Store (iOS).



Android



iOS

KINOMAP

Download the Kinomap app using the QR code or search for the app on Google Play Store (android) or App Store (iOS).



Android



iOS

ZWIFT

Download the Zwift app using the QR code or search for the app on Google Play Store (android) or App Store (iOS).



Android



iOS

Note. Due to constant app updates and development, we are unable to provide support or guarantee support with your smart device. For any questions, we recommend contacting the application developer.

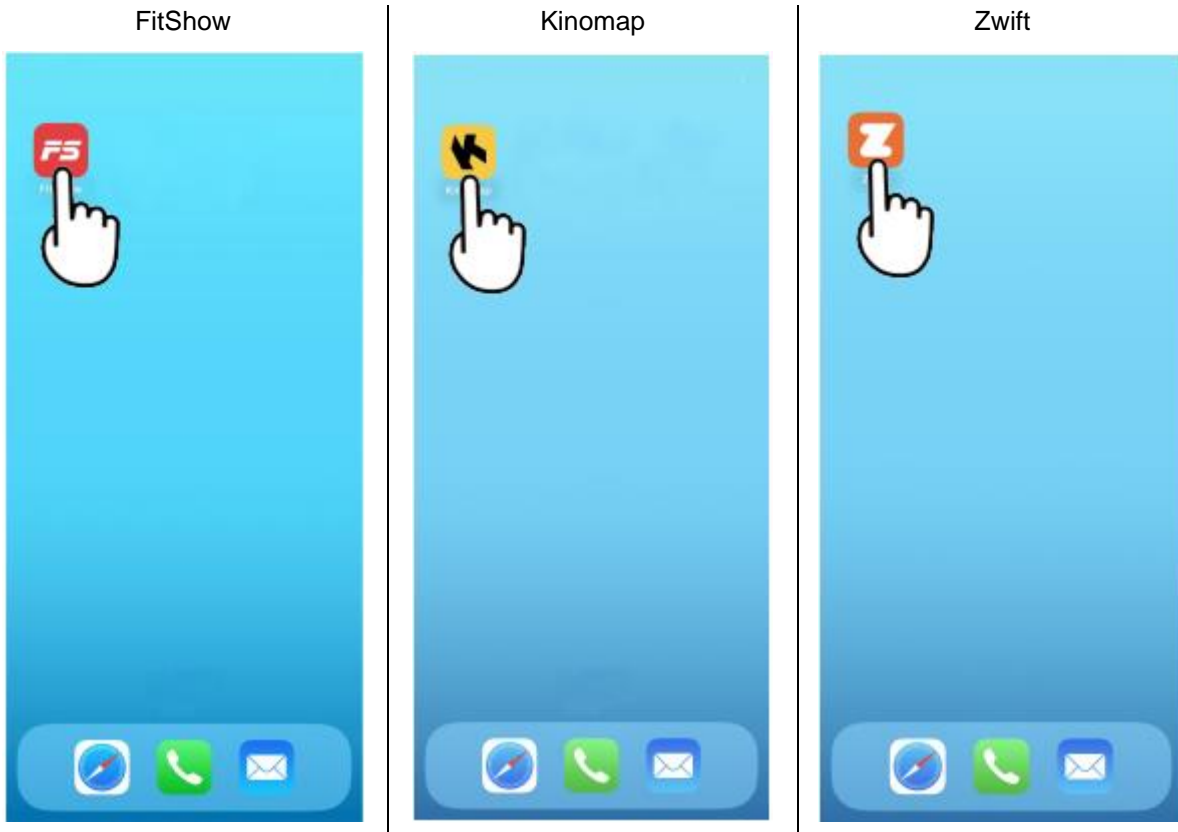

TRANSPORT

Warning: Due to the size and weight of the device, we recommend asking another person for help.

Grasp the machine by the rear handles (1) and tilt it onto the transport wheels (2), which are located on the front stabilizer.

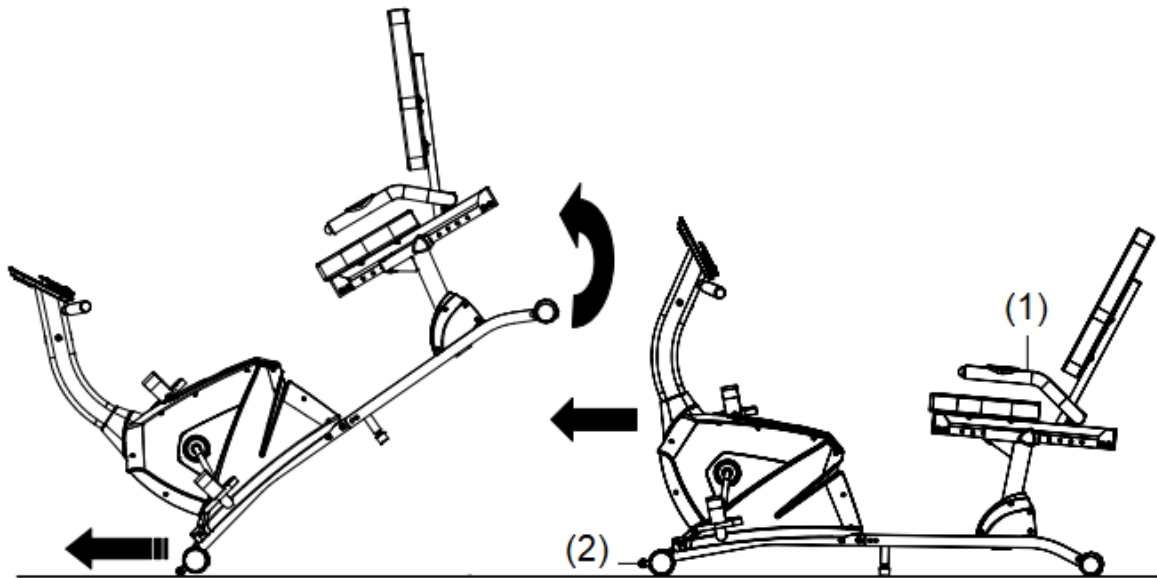

ADJUSTMENTS

Resistance setting

You can adjust the resistance of the device using the rotary knob. Turn clockwise to increase the resistance. Turn counter-clockwise to reduce the resistance.

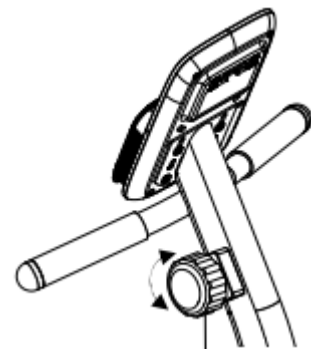

Leveling

Use the rear stabilizer to level the machine so that it is stable during use.

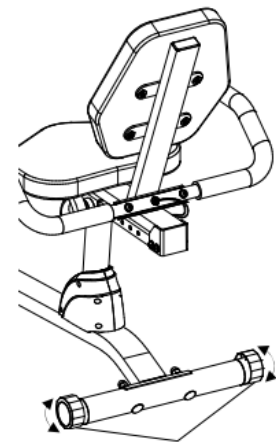

Seat position

Loosen the hand knob (1) counterclockwise. Loosen the hand knob (2) counterclockwise and pull it out. Adjust the position of the seat and secure it in position using the screw (2). Secure both hand knobs.

Warning: Make sure both hand knobs are secured before use.

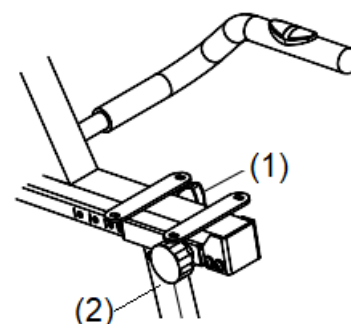

ADVANTAGES OF RECUMBITION

Recumbents are an excellent choice when it comes to stabilizing the lumbar back of your back, as you sit back while training on exercise bike you bend forward. Recumbent therefore supports better body holding.

Recumbents are also more favorable to your joints. The bottom of the back is laid on a large, stable saddle, and your knees and ankles are protected from possible injury.

The fact that the saddle is larger is often the biggest difference compared to classical exercise bike. Just the comfort of sitting is the difference that everyone who experiences this type of exercise bike will feel.

Recumbent is also a good option for most people with neurological disorders. If your back or joints suffer from rheumatoid arthritis, recumbent may be the best solution for you because of the weight distribution of your body.

EXERCISING INSTRUCTIONS

A successful workout begins with warm-up exercises and ends with cool-down (relaxing) exercises. The warm-up exercises should make your body ready for the main workout. The cool-down phase should protect your muscles from injuries and cramps. Do warm-up and cool-down exercises as shown in the chart below.



Touching your toes

Slowly bend your back from hips. Keep your back and arms relaxed while stretching downwards to your toes. Do it as far as you are able and hold the position for 15 seconds. Bend your knees slightly.



Upper thigh

Lean against a wall with one hand. Reach down and behind you. Lift up your right or left foot to your buttock as high as possible. Keep for 30 seconds and repeat twice for each leg.



Hamstring stretched

Sit and outstretch your right leg. Rest the sole of your left foot against the inside of your right thigh. Stretch out your right arm along your right leg as far as you can. Hold for 15 seconds and relax. Repeat all with your left leg and left arm.



Inside upper thigh

Sit on the floor and place your feet together. Knees are pointed outwards. Pull your feet as close as possible to your groin. Press your knees carefully downwards. Keep this position for 30-40 seconds if possible.



Calves and Achilles tendon

Lean against a wall with your left leg in front of the right one and your arms forward. Stretch out your right leg and keep your left foot on the floor. Bend your left leg and lean forwards by moving your right hip in the direction of the wall. Hold for 30-40 seconds. Keep your leg stretched and repeat exercising with other leg.

MAINTENANCE

- Clean with a soft cloth and a non-aggressive cleaner.
- Do not use aggressive cleaning agents.
- Only wipe the electrical parts with a cloth. Avoid contact with water.

STORAGE

Keep the recumbent in a clean and dry environment. Make sure the power switch is turned off and the exercise bike is not plugged into the power socket.

IMPORTANT NOTICE

- This exercise bike comes with standard safety regulations. Any other use is prohibited and may be dangerous to users. We are not responsible for any injury caused by improper and forbidden use of the machine.
- Consult your doctor before starting training on the exercise bike. Your doctor should evaluate whether you are physically fit to use the machine and how much effort you are able to undergo. Incorrect exercise or switching of the body can harm your health.
- Carefully read the following tips and exercises. If you experience pain, nausea, breathing, or other health problems during exercise, immediately stop the exercise. If the pain persists, contact your doctor immediately.
- This exercise bike is not suitable as a professional or medical purpose. It can also not be used for healing purposes.
- The heart rate monitor is not a medical device. It provides only approximate information about your average heart rate, and any suggested pulse rate is not medically binding. Accumulated data may not always be accurate regarding uncontrollable human and environmental factors.

ENVIRONMENT PROTECTION

After the product lifespan expired or if the possible repairing is uneconomic, dispose it according to the local laws and environmentally friendly in the nearest scrapyard.

By proper disposal you will protect the environment and natural sources. Moreover, you can help protect human health. If you are not sure in correct disposing, ask local authorities to avoid law violation or sanctions.

Don't put the batteries among house waste but hand them in to the recycling place.

TERMS AND CONDITIONS OF WARRANTY, WARRANTY CLAIMS

General Conditions of Warranty and Definition of Terms

All Warranty Conditions stated here under determine Warranty Coverage and Warranty Claim Procedure. Conditions of Warranty and Warranty Claims are governed by Act No. 89/2012 Coll. Civil Code, and Act No. 634/1992 Coll., Consumer Protection, as amended, also in cases that are not specified by these Warranty rules.

The seller is SEVEN SPORT s.r.o. with its registered office in Strakonická street 1151/2c, Prague 150 00, Company Registration Number: 26847264, registered in the Trade Register at Regional Court in Prague, Section C, Insert No. 116888.

According to valid legal regulations it depends whether the Buyer is the End Customer or not.

“The Buyer who is the End Customer” or simply the “End Customer” is the legal entity that does not conclude and execute the Contract in order to run or promote his own trade or business activities.

“The Buyer who is not the End Customer” is a Businessman that buys Goods or uses services for the purpose of using the Goods or services for his own business activities. The Buyer conforms to the General Purchase Agreement and business conditions.

These Conditions of Warranty and Warranty Claims are an integral part of every Purchase Agreement made between the Seller and the Buyer. All Warranty Conditions are valid and binding, unless otherwise specified in the Purchase Agreement, in the Amendment to this Contract or in another written agreement.

Warranty Conditions

Warranty Period

The Seller provides the Buyer a 24 months Warranty for Goods Quality, unless otherwise specified in the Certificate of Warranty, Invoice, Bill of Delivery or other documents related to the Goods. The legal warranty period provided to the Consumer is not affected.

By the Warranty for Goods Quality, the Seller guarantees that the delivered Goods shall be, for a certain period of time, suitable for regular or contracted use, and that the Goods shall maintain its regular or contracted features.

Batteries

6-month battery warranty – we guarantee that battery's nominal capacity does not fall below 70% of its total capacity within 6 months of the product's sale.

The Warranty does not cover defects resulting from (if applicable):

- User's fault, i.e. product damage caused by unqualified repair work, improper assembly, insufficient insertion of seat post into frame, insufficient tightening of pedals and cranks
- Improper maintenance
- Mechanical damages
- Regular use (e.g. wearing out of rubber and plastic parts, moving mechanisms, joints, wear of brake pads/blocks, chain, tires, cassette/multi wheel etc.)
- Unavoidable event, natural disaster
- Adjustments made by unqualified person
- Improper maintenance, improper placement, damages caused by low or high temperature, water, inappropriate pressure, shocks, intentional changes in design or construction etc.

Warranty Claim Procedure

The Buyer is obliged to check the Goods delivered by the Seller immediately after taking the responsibility for the Goods and its damages, i.e. immediately after its delivery. The Buyer must check the Goods so that he discovers all the defects that can be discovered by such check.

When making a Warranty Claim the Buyer is obliged, on request of the Seller, to prove the purchase and validity of the claim by the Invoice or Bill of Delivery that includes the product's serial number, or eventually by the documents without the serial number. If the Buyer does not prove the validity of the Warranty Claim by these documents, the Seller has the right to reject the Warranty Claim.

If the Buyer gives notice of a defect that is not covered by the Warranty (e.g. in the case that the Warranty Conditions were not fulfilled or in the case of reporting the defect by mistake etc.), the Seller is eligible to require a compensation for all the costs arising from the repair. The cost shall be calculated according to the valid price list of services and transport costs.

If the Seller finds out (by testing) that the product is not damaged, the Warranty Claim is not accepted. The Seller reserves the right to claim a compensation for costs arising from the false Warranty Claim.

In case the Buyer makes a claim about the Goods that is legally covered by the Warranty provided by the Seller, the Seller shall fix the reported defects by means of repair or by the exchange of the damaged part or product for a new one. Based on the agreement of the Buyer, the Seller has the right to exchange the defected Goods for a fully compatible Goods of the same or better technical characteristics. The Seller is entitled to choose the form of the Warranty Claim Procedures described in this paragraph.

The Seller shall settle the Warranty Claim within 30 days after the delivery of the defective Goods, unless a longer period has been agreed upon. The day when the repaired or exchanged Goods is handed over to the Buyer is considered to be the day of the Warranty Claim settlement. When the Seller is not able to settle the Warranty Claim within the agreed period due to the specific nature of the Goods defect, he and the Buyer shall make an agreement about an alternative solution. In case such agreement is not made, the Seller is obliged to provide the Buyer with a financial compensation in the form of a refund.

CZ
SEVEN SPORT s.r.o.

Registered Office: Strakonická 1151/2c, Praha 5, 150 00, ČR
Headquarters: Dělnická 957, Vítkov, 749 01
Warranty & Service: Čermenská 486, Vítkov 749 01

CRN: 26847264
VAT ID: CZ26847264
Phone: +420 556 300 970
E-mail: eshop@insportline.cz
reklamace@insportline.cz
servis@insportline.cz

Web: www.inSPORTline.cz

SK
inSPORTline s.r.o.

Headquarters, warranty & service center: Električná 6471,
Trenčín 911 01, SK

CRN: 36311723
VAT ID: SK2020177082
Phone: +421(0)326 526 701
E-mail: objednavky@insportline.sk
reklamacie@insportline.sk
servis@insportline.sk

Web: www.inSPORTline.sk

About shipping

